

Single-Acting High Tonnage Cylinders - SHT series

Doc. : L1035A Date : 2019/01

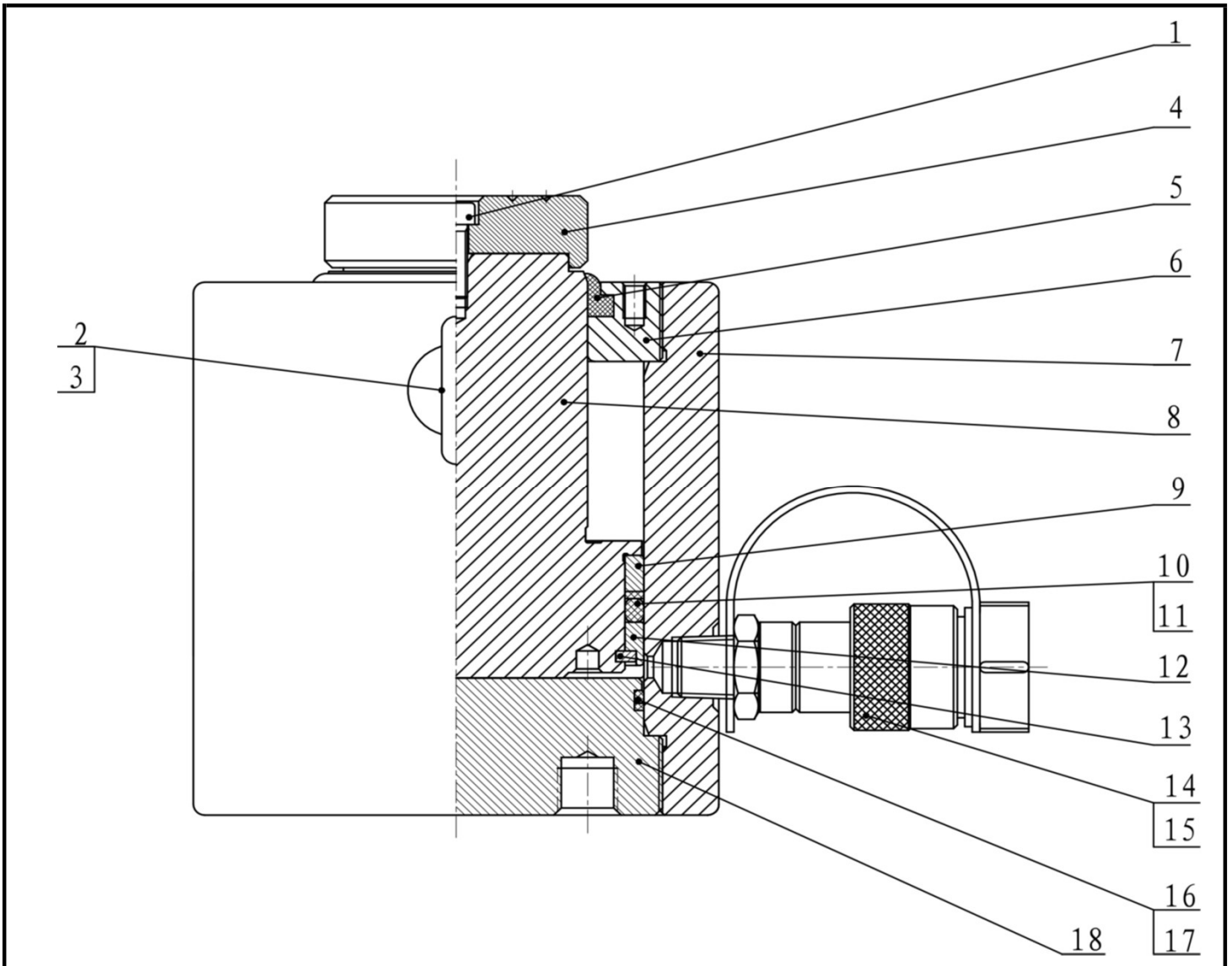

Item NO.	Description	Qty	Part NO.			
			SHT100-50	SHT100-100	SHT100-150	SHT100-200
1	Hexagon socket head cap screws	1				●
2	Lifting bolt (Item #3 included)	2		1.3.009.00005		
3	Hexagon nut	2		-		
4	Lifting head	1		2.001.00092		
5	J-dustband	1				●
6	Guide cap	1		2.001.02933		
7	Oil cylinder	1		2.001.03326 (SHT100-50)		
		1		2.001.03328 (SHT100-100)		
		1		2.001.01245 (SHT100-150)		
		1		2.001.03330 (SHT100-200)		
8	Piston rod	1		2.001.03327 (SHT100-50)		
		1		2.001.03329 (SHT100-100)		
		1		2.001.01246 (SHT100-150)		
		1		2.001.03331 (SHT100-200)		
9	Front guide sleeve	1		2.001.02934		
10	Backup Washer	1				●
11	O-ring	1				●
12	Back guide sleeve	1		2.001.00139		
13	Semi-ring	1		2.001.00009		
14	Female connector	1		1.3.025.00004		
15	Connector protective jacket for NPT3/8"	1		1.3.097.00002		
16	Backup Washer	1				●
17	O-ring	1				●
18	Bottom cap	1		2.001.00065		
●	Repair kit	1				SHT100-RK