

Double-Acting High Tonnage Cylinders - DRC series

Doc. : L1017A Date : 2018/12

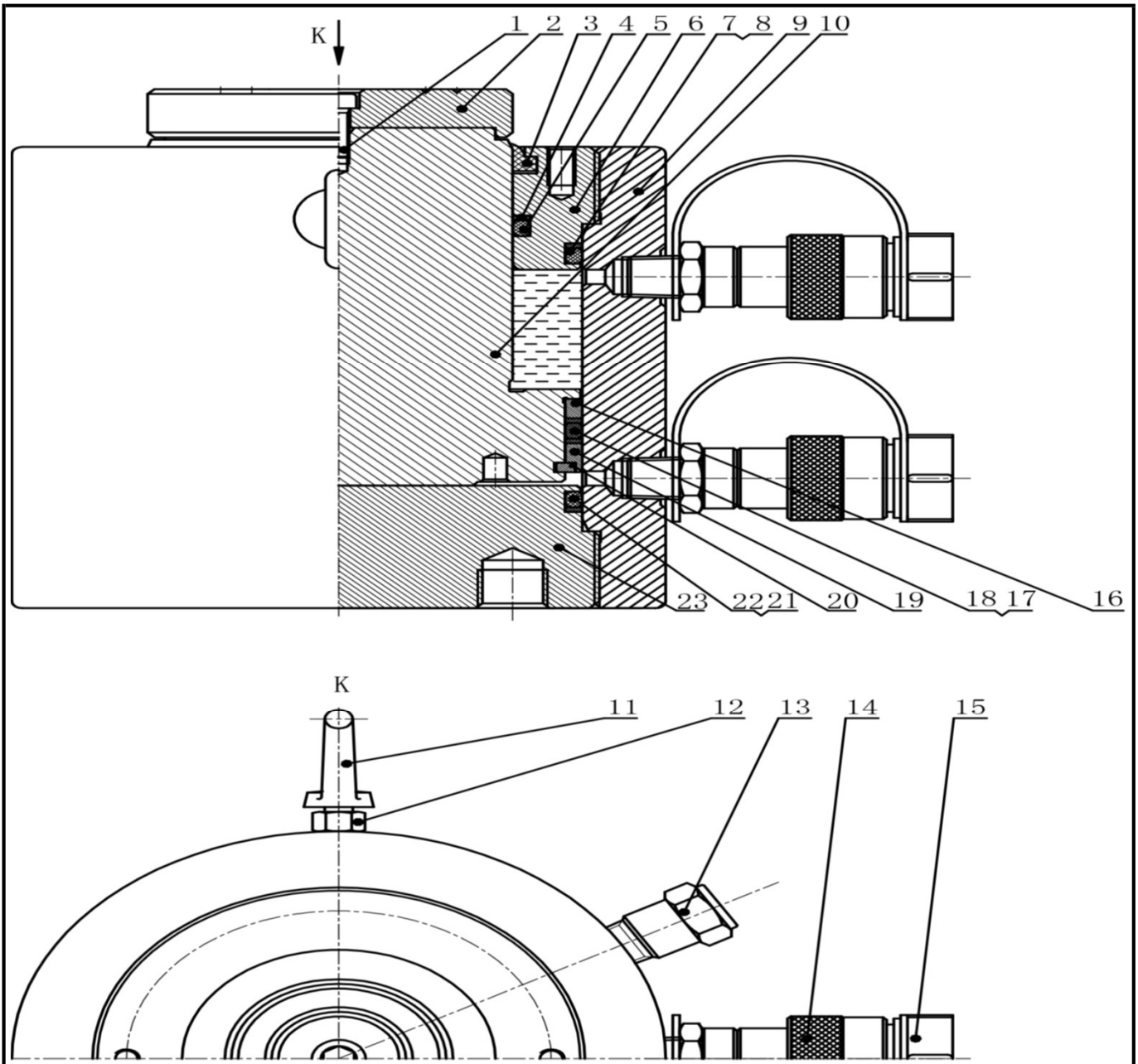

Item NO.	Description	Qty	Part NO.		
			DRC500-100	DRC500-200	DRC500-300
1	Hexagon socket head cap screws	1		●	
2	Lifting head	1		2.001.00095	
3	J-dustband	1		●	
4	Backup Washer	1		●	
5	O-ring	1		●	
6	Guide cap	1		2.001.00040	
7	Backup Washer	1		●	
8	O-ring	1		●	
9	Oil cylinder	1		2.001.03341 (DRC500-100)	
		1		2.001.00280 (DRC500-200)	
		1		2.001.02942 (DRC500-300)	
10	Piston rod	1		2.001.03342 (DRC500-100)	
		1		2.001.00159 (DRC500-200)	
		1		2.001.02943 (DRC500-300)	
11	Lifting bolt (Item #12 included)	2		1.3.009.00003	
12	Hexagon nut	2		-	
13	Safety valve	1		2.008.00047	
14	Female connector	2		1.3.025.00004	
15	Connector protective jacket for NPT3/8"	2		1.3.097.00002	
16	Front guide sleeve	1		2.001.00229	
17	Backup Washer	2		●	
18	O-ring	1		●	
19	Back guide sleeve	1		2.001.00142	
20	Semi-ring	1		2.001.00013	
21	Backup Washer	1		●	
22	O-ring	1		●	
23	Bottom cap	1		2.001.00068	
●	Repair kit	1		DRC500-RK	